

## DATALOGGERS 3634 and 3660

*A rugged unit for reading standard Aanderaa sensors and for displaying, storing and transmitting the data in engineering units.*

*Datalogger 3634, 5 channels  
Datalogger 3660, 18 channels*



The Dataloggers 3660 and 3634 are low power, lightweight and watertight field operating devices displaying data in engineering units. They are designed for battery operation and can operate with all Aanderaa standardized sensors. The 3660 and 3634 units scans up to 17 or 4 sensors respectively making them well suited for a variety of field datalogging applications such as Automatic Weather Stations, Road Weather Stations, Wind Monitoring Systems and Water Level Measuring Systems.

Data can be transmitted as raw-data in 10-bit code by VHF or UHF-radio, or as engineering units by modem. Data can also be presented as a voice message by connecting Voice Generator 3420. If connected directly to a PC, or via modem, the Display Program 3710 can be used for real-time data display.

When the unit is connected to a modem, alarm limits can be set for each sensor connected. When an alarm is triggered the unit can dial a preset telephone number and send an alarm message to another modem or to a pager.

The electronic circuit-board is molded in Scotchcast, housed in an 28x178x271mm anodized aluminum cover, designed for wall mounting. It is furnished with a 4-line 40 character LCD, two control switches and a set of watertight receptacles for electrical connection. If power is lost the unit will retain its programmed information and data due to an internal back-up battery.

A built-in quartz clock generates the trigger pulse for the unit. Selectable recording intervals are : 0.5, 1, 2, 5, 10, 20, 30, 60, 120 and 180 minutes.

The unit also has a non-stop mode and a remote-start mode. In the latter case a single measurement cycle is performed on reception of a remote triggering signal.

When triggered by the clock or by a remote-start signal, the unit scans up to 18 channels in sequence. Channel 1 is a

built-in reference channel, while the other is for connecting sensors. The analog to digital converter converts the sensor readings into raw data in 10-bit binary code which is fed to the PDC-4 output.

When operating the readings are displayed successively in engineering units on an LCD and at the same time stored in the units internal memory. After measuring the last channel, the display will go blank until the unit is triggered again. The stored data can be accessed directly from a personal computer or over the telephone network by connecting the unit to a modem.

The Last Reading output will send an ASCII string after each channel has been measured, containing the channel number, parameter name, reading and unit for each channel (see page 6).

Although the dataloggers are either 5 or 18 channel loggers the first channel is always allocated a reference reading which is a number between 0 and 1023. This is a fixed reading in the beginning of every measuring cycle and it serves as a station identification number as well as a performance test. If a special number is needed as reference value, coefficients can be entered for this channel as for the other channels. The other channels are available for sensors.

**Safety back-up** of raw data, in addition to the internal stored data in engineering units, is recommended using an external data storage unit DSU 2990,2990E or 2990F. The 2990 version can store up to 65000 data words, the 2990E version up to 262000 data words and these versions will, when full, block for further data storage. The 2990F version, however, will continue to store data but then overwrite the oldest ones. The same storage units are also used for **long-term data storage** exceeding the internal storage capacity.

**Storage Capacity. days** The figures are estimated values and must be considered as a guideline.

Interval minutes	Number of Channels																
	2	3	4	5	6	7	8	9	10	11	12	13	14	15	16	17	18
0,5	5	4	4	3	3	3	—	—	—	—	—	—	—	—	—	—	—
1	10	9	8	6	6	5	5	4	4	4	4	3	3	—	—	—	—
2	19	17	15	12	11	10	10	9	8	8	7	6	6	6	6	5	5
5	48	42	38	31	28	26	24	21	20	19	18	16	15	15	14	13	13
10	96	84	75	62	56	52	48	42	40	38	36	32	31	30	28	26	25
20	190	167	149	122	112	104	96	84	80	75	71	64	62	59	56	52	50
30	282	248	221	182	167	155	144	126	119	112	106	96	92	88	84	78	75
60	543	480	430	355	327	303	282	248	234	221	210	190	182	174	167	155	149
120	1003	896	809	677	626	582	543	480	454	430	408	372	355	341	327	303	292
180	1379	1248	1138	965	896	836	784	696	659	626	596	543	520	499	480	445	430

The drawings below shows three typical applications of the Dataloggers. The sensors are connected directly to the datalogger. At preset intervals the datalogger will read the sensors and display the readings, channel by channel, in engineering units on the LCD. Connected to the telephone line, data are available as ASCII coded text from the modem. If alarm limits are set and triggered, the unit will automatically dial a programmed telephone number and send a message as ASCII coded text to another modem, or a 7 digit code to a pager.

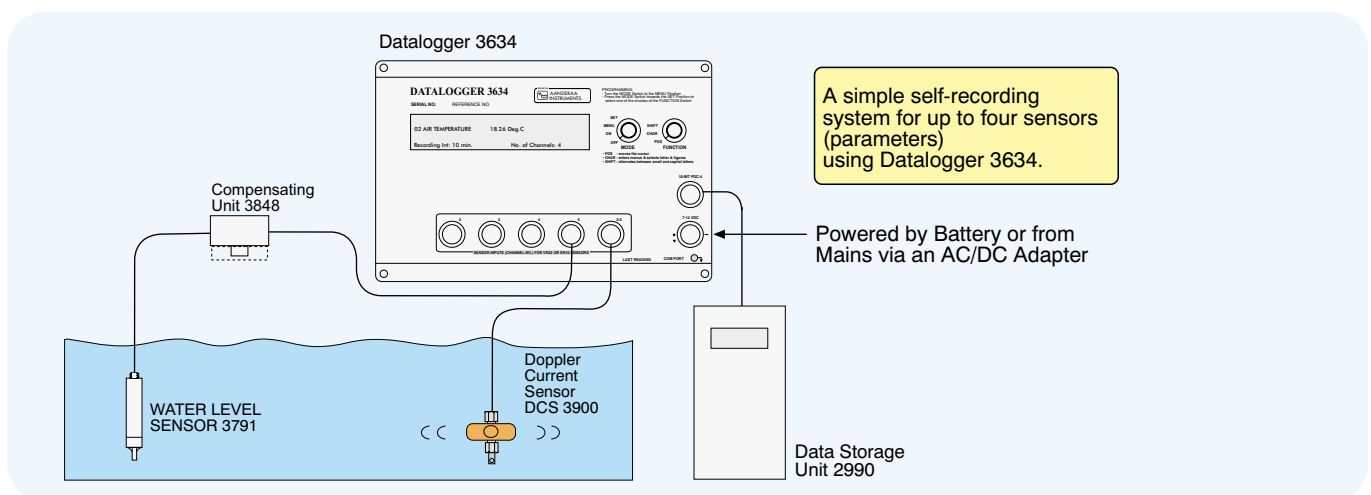
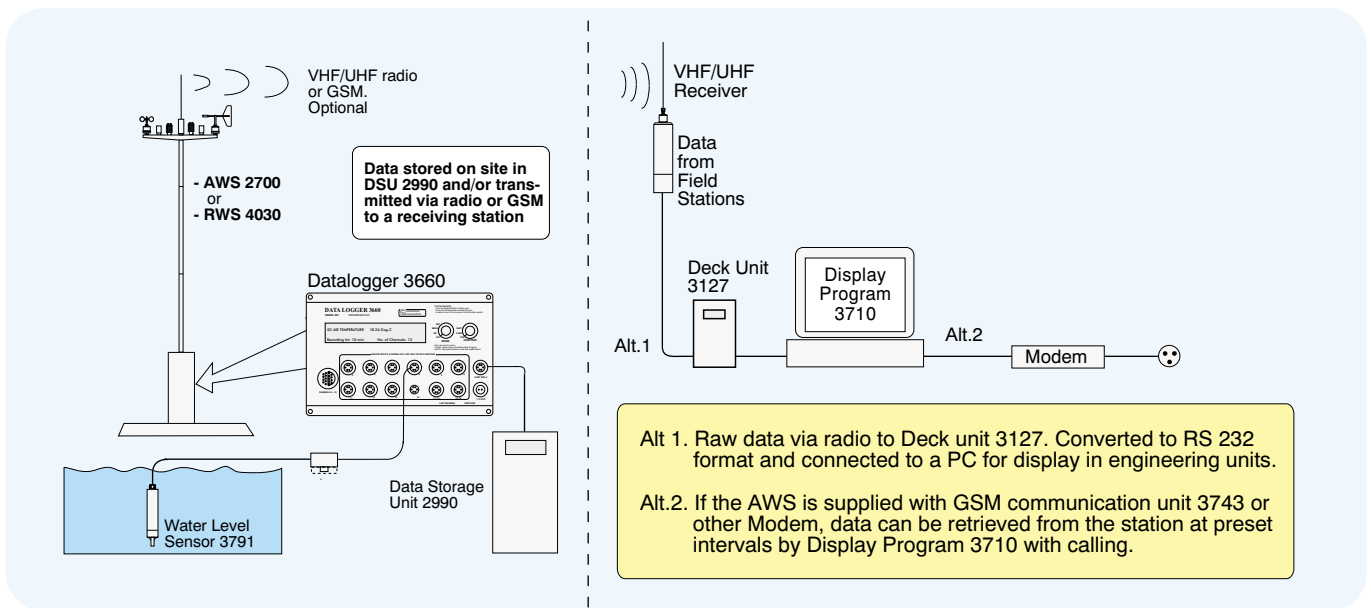
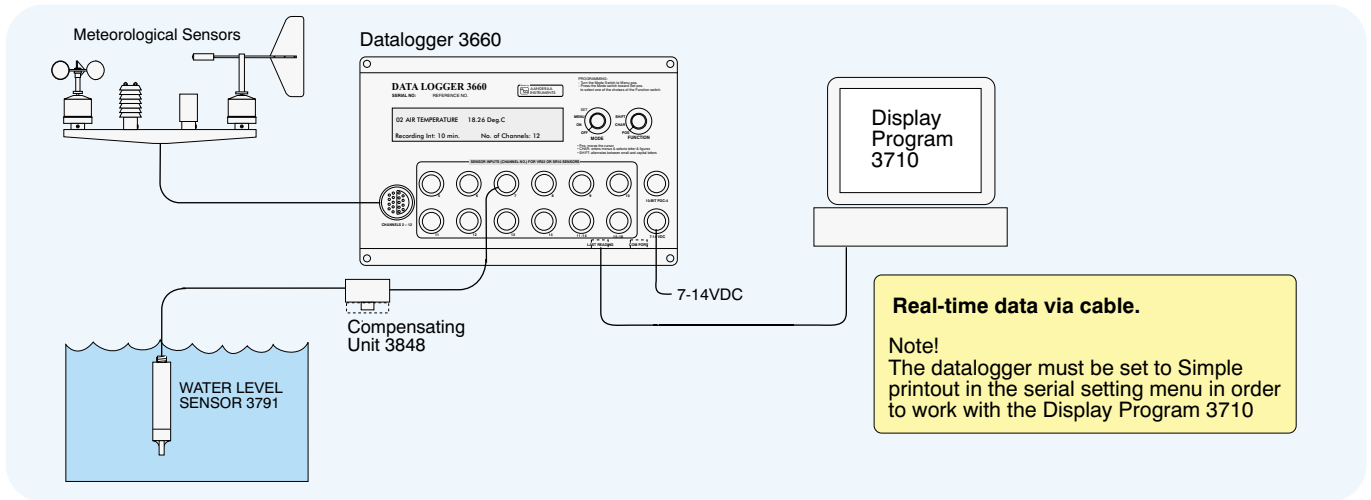

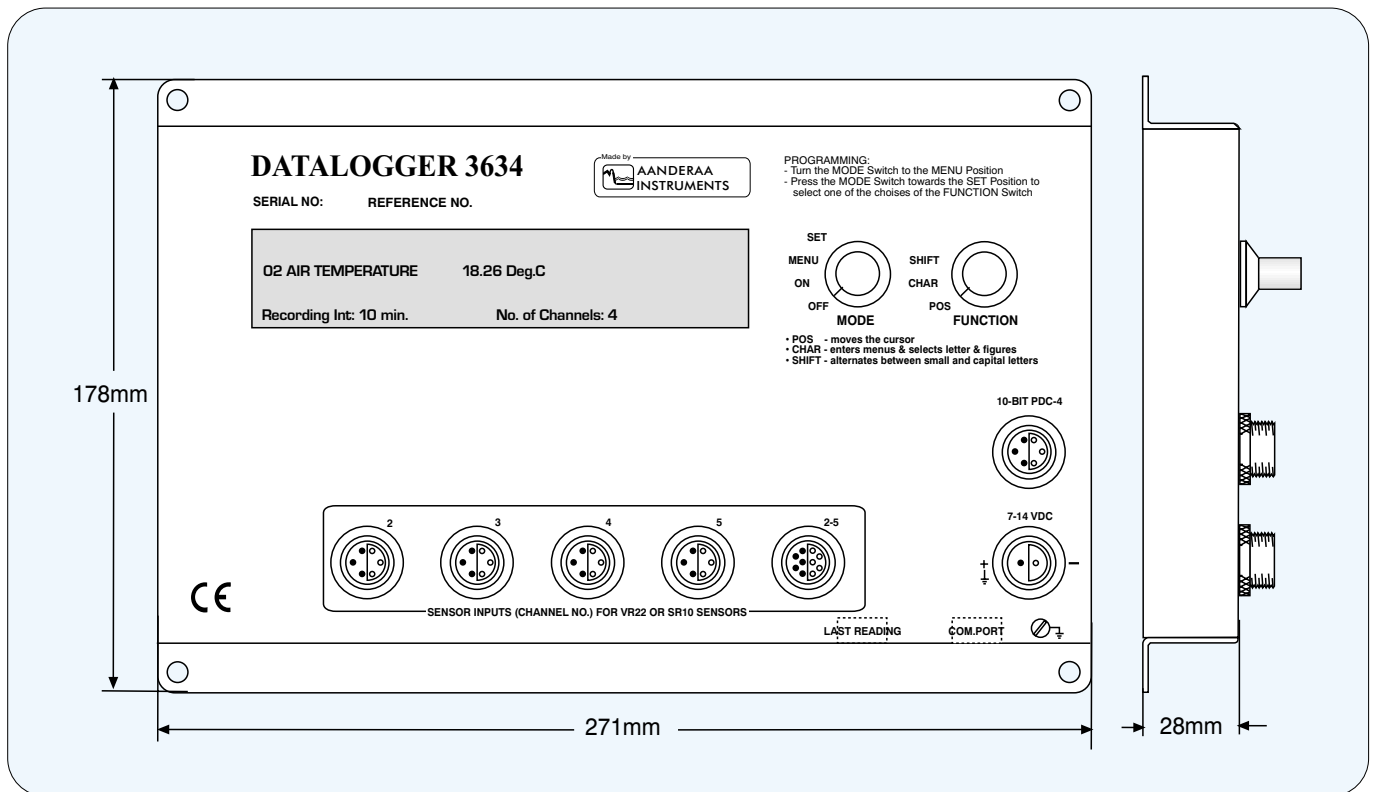
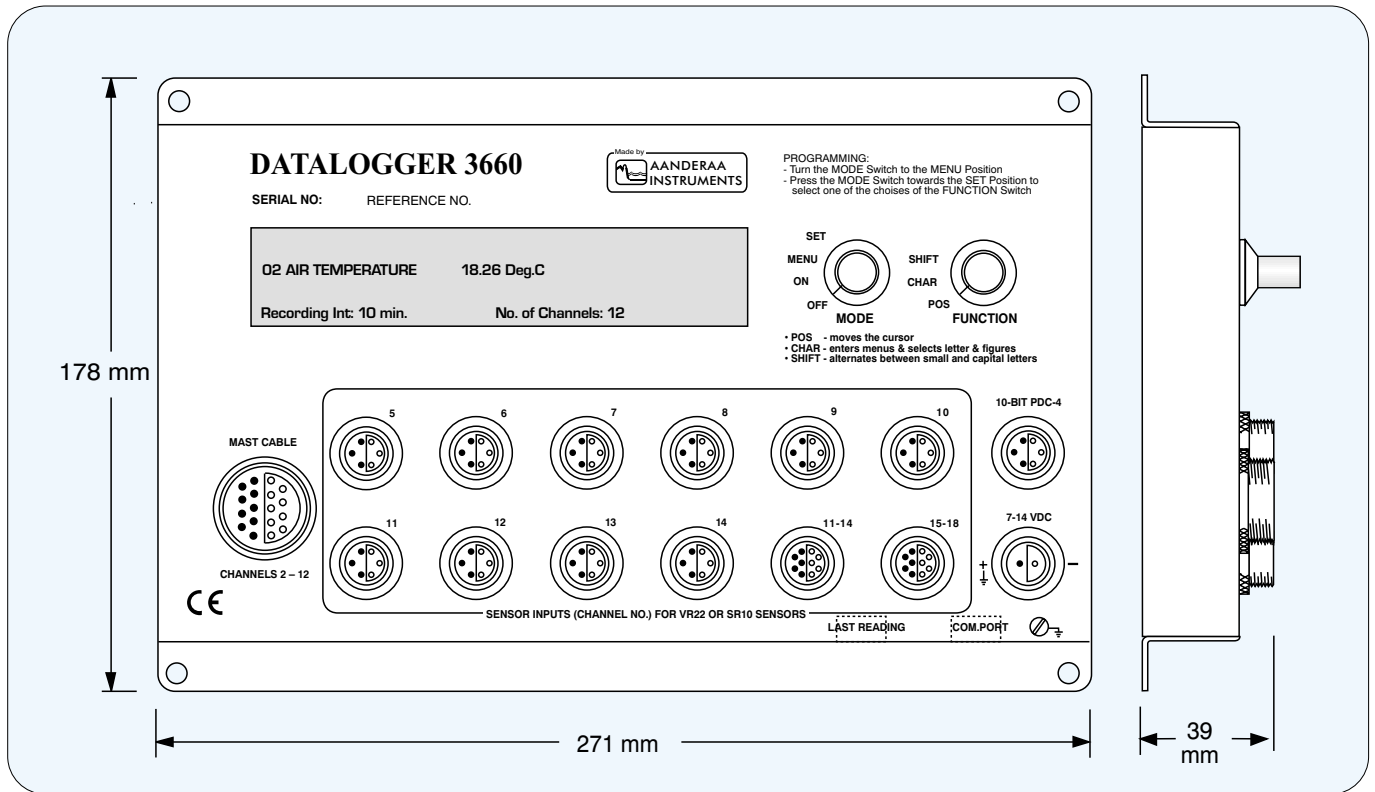

**PROGRAMMING**

To convert raw data into engineering units, the parameter names, units and the calibration coefficients must be entered into the datalogger. The coefficients for the individual sensors are given in the calibration sheet following each sensor. Programming is normally done at the factory prior to delivery but can also be done by the user following the instructions below.

Each datalogger is delivered with a comprehensive operating manual, Technical description TD 200, giving detailed instructions how to program the datalogger.

The easiest way to program the dataloggers is to use a Personal Computer with hyperterminal and connect cable 3204 from the COM PORT to the computer's serial port. When connecting the cable to the unit and turning the Mode Selector switch to MENU position a menu will appear on the screen. Your menu choice is accepted after pressing "ENTER".

Another way of programming is by means of the two control switches on the front of the unit.

To enter the programming mode, turn the Mode Switch to the MENU position. A menu will appear on the display and the cursor will be placed at the first menu-choice.

- 1.- To move the cursor to another menu-choice, set the Function Switch in the POS position and then press the Mode Switch towards the SET position.
- 2.- To enter a menu or to select letters and figures, set the Function Switch to the CHAR position and press the Mode Switch towards the SET position.
- 3.- To alter between capital and small letters set the Function Switch in the SHIFT position and then press the Mode Switch towards the SET position.

To simplify programming the "repeat" function will be activated if the Mode Switch is held in the SET position.

The unit can also be programmed by modem. To get access to the programming mode type SETUP at the

**An example of data from the COM PORT.**

When the station is dialed, the last measurement is first received. Then, if the command "LIST" is given at the command prompt followed by starting and stopping time, a selectable list of historical data will be received. Time of operation before the internal memory is full will depend on the recording interval and the number of channels.

See table page 2.

command prompt, followed by ENTER and when asked for, type the password 3660 or 3634. A menu will appear on the screen and your menu choice is accepted after pressing "ENTER".

If no characters are entered within two minutes, the unit will leave the programming mode and hang-up.

**OPERATING PROCEDURE**

When turned ON, the unit will start immediately showing the recording interval and the number of channels. Then the unit will scan the channels in sequence and the LCD will display the result in engineering units.

**02 AIR TEMPERATURE 9.23 Deg.C**

**Recording int: 10 min No. of channels 12**

*Example of display of data (displayed for 4 seconds)*

Between recording intervals, operating one of the two selector switches will wake up the unit. Menus can then be selected without interfering with the recording interval and the last measurement can be viewed together with the battery voltage and elapsed time since last measurement.

**OUTPUT SIGNALS**

The unit has three output receptacles. One 6-pin receptacle for raw data in the PDC-4 code. One for connection to a PC or Voice Generator 3420, giving only the last reading, and one COM PORT for programming and connection of modem.

When dialing a Datalogger from a modem the last measurement will be received. If a list of historical data is wanted this can be achieved by typing the command "LIST" at the command prompt within 10 seconds after the last measurement has been received.

```

DATALOGGER 3660
OWNER'S NAME
Location, Recording interval:10 min.Date: 23/3-1999
-----
Parameter Unit Reading
-----
2 Water Level m 7.5
3 Water Temperature Deg.C 11.1
4 Wind Speed m/s 9.5
5 Wind Direction Deg.M 176.5
6 Air Temperature Deg.C 16.5
----- A System from Aanderaa Instruments -----
Command>List_199903231040_-_199903231020
Year Month Day
1999 03 23
Time Ref CH02 CH03 CH04 CH05 CH06
10:40 322 7.5 11.1 9.5 176.5 16.5
10:30 322 7.4 11.1 9.3 182.0 16.4
10:20 322 7.4 11.0 9.2 180.2 16.4
    
```

N.B. \_= Space

**PIN CONFIGURATION**

Receptacle, exterior view; pin = ●; bushing = ○

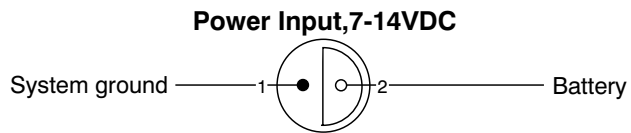
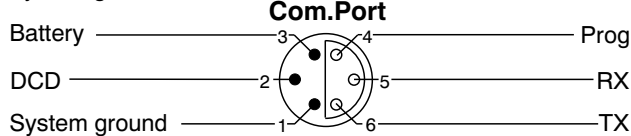
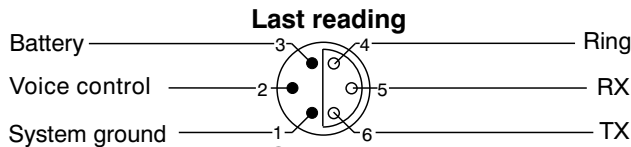
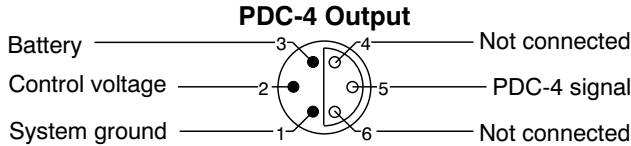
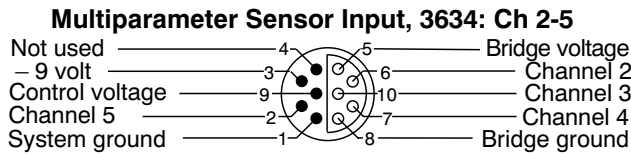
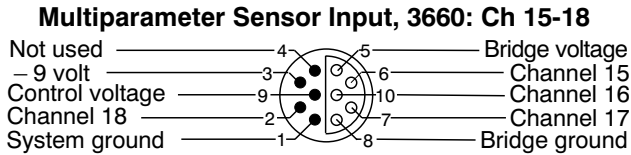
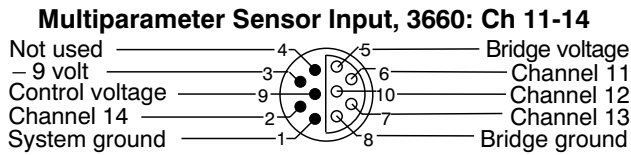
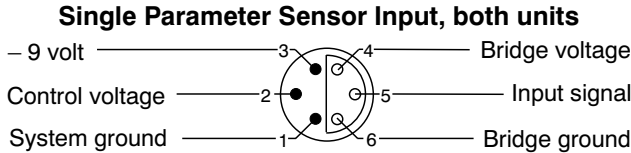
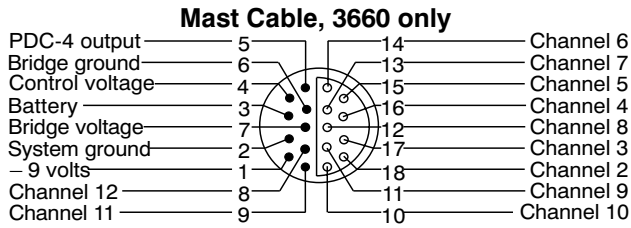

Input signal, 3660: Up to 17 VR22 or SR10 sensors  
 3634: Up to 4 VR22 or SR10 sensors  
 Recording intervals: 0.5, 1, 2, 5, 10, 20, 30, 60, 120, 180 minutes. In addition: nonstop and remote start. 4 seconds each channel

Remote Start: 5V positive pulse to pin 5 of the PDC-4 output receptacle  
 Resolution: 10 bit binary  
 Accuracy: ±1bit binary  
 Battery indication: Range: 6-15 V

Output signals:  
 Aanderaa code: 10 bit PDC-4  
**LAST READING and COM PORT:** ASCII coded selectable from 1200 to 9600 baud, 8 data bit, 1 stop bit, no parity, no handshake. RS-232C string, See below

Internal storage: RAM. ( See table page 2)  
 Power Supply: 7-14 volt DC  
 Current consumption: Quiescent: 50µA, 15mA average when operating  
 Operating temp.: -40 to +60°C  
 LCD: -15 to +60°C

Material and finish: Scotchcast molding with hard anodized aluminum case, 10-15µ  
 Weight: 1.9kg

Warranty: Two years against faulty materials and workmanship

Accessories included: Data/Programming Cable 3204  
 optional: AC/DC Adapter 3786

Approvals: **CE** certified

Ready made cables are available for connecting the Dataloggers to:

DSU 2990 .....	Cable 2842
Voice Generator 3420 .....	Cable 3296
PC/CRT .....	Cable 3204
Field Modem 3431 .....	Cable 2842
Printer (Epson) .....	Cable 3206
Printer (Seiko) .....	Cable 3279
External Modem, 25 pins .....	Cable 3205

Representative's Stamp

RS-232C String, Available on Last Reading receptacle:

01 Reference 834.00  
 02 Water level 3.43 m

Protocol:

CHANNEL NO.: 2 CHAR.<SPACE>. PARAMETER NAME: 19 CHAR. <SPACE>

READING: 5 CHAR. <POINT> DECIMALS: 2 CHAR.<SPACE> UNIT: 5 CHAR.<LF>& <CR> WITH AN EXTRA <LF>& <CR> AFTER THE LAST CHANNEL.

Printout of time and battery voltage is optional

Latest version is on the Internet

PO BOX 160, NESTTUN  
 5852 BERGEN, NORWAY

NESTTUNBREKKEN 97  
 5221 NESTTUN, NORWAY

TEL. +47 55 109900  
 FAX. +47 55 109910

E-MAIL: info@aanderaa.no  
 WEB: http://www.aanderaa.com