

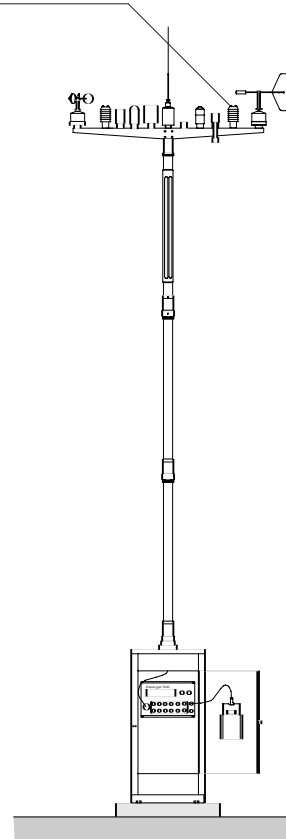

RELATIVE HUMIDITY SENSOR 3445

is designed for use with the Aanderaa Automatic Weather Station 2700, Dataloggers 3660 or 3634 and other sensor read-out units.



Automatic Weather Station AWS 2700

Relative Humidity is one of the basic parameters in meteorology and a Relative Humidity (RH) Sensor will normally be included in a weather station. Sensor 3445 is designed to fit Aanderaa Automatic Weather Station 2700, but can also be used as a separate unit.

The 3445 sensor consists of the RH Probe 3447 and a Radiation Screen 3446. The probe has a sensing element at one end, a 6-pin receptacle at the other and an electronic board in between, all of which are molded in durotong foam into a cylindrically shaped probe.

The probe is furnished with a standard Aanderaa sensor foot to which the screen is fastened. The screen protects

the probe against direct sunshine and rain. The RH Sensor 3445 is based upon an integrated circuit, IH-3602-L from Hy-Cal Engineering, as the sensing element. The circuit employs the well proven capacitive polymer to sense humidity.

The sensor also incorporates a millipore filter which reduces the atmospheric pollution of the sensing element to a minimum.

The circuit has a linear output voltage of between 0 — 100% relative humidity. A built-in AD converter and a micro-controller changes this voltage to the standard Aanderaa SR10 digital output signal.

SPECIFICATIONS FOR RELATIVE HUMIDITY SENSOR 3445 AANDERAA INSTRUMENTS

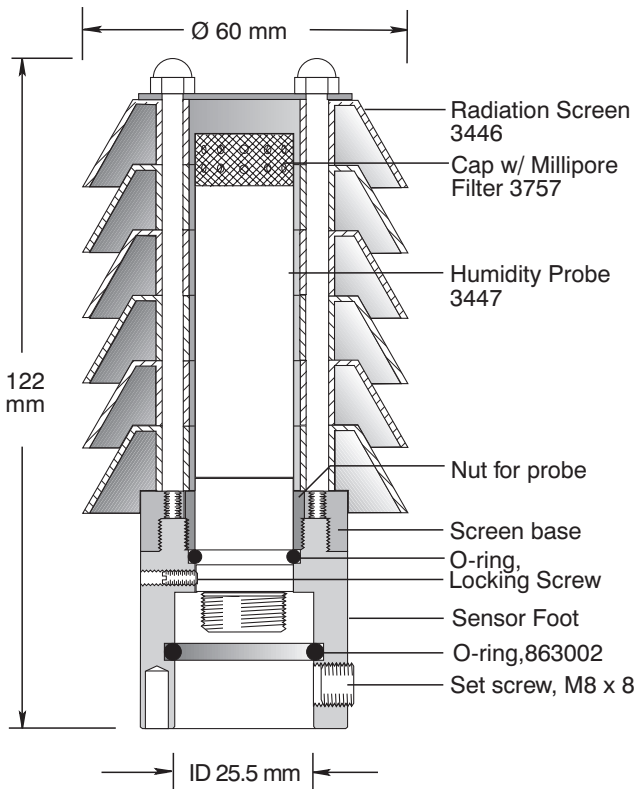

Range: 0 to 100% relative humidity (RH)
Accuracy: ±2% RH
Resolution: 0.1%
Sensing Element: IH-3206-L
Sensor Output: Digital SR10
Operating Temperature: -40 to + 50°C
Time Constant: 1.5 minutes
Current Consumption: Maximum 1.2 mA when operating
Electrical Connection: Automatic Weather Station 2700's Sensor Cross Arm (Watertight Plug 2828)

Material and Finish:
Probe: Durotong foam and titanium
Radiation Screen: White nylon
Dimensions: Radiation Screen, Ø 60x 128 mm
Net Weight: 140 grams
Gross Weight: 500 grams
Packing: Cardboard box, 300x200x210mm
Warranty: Two years against faulty materials and workmanship

Note! Check the millipore filter for contamination from time to time depending on the grade of pollution in the area and replace if necessary.

Connecting Cable 2842 (10 meter cable with watertight plugs), is available for connecting this sensor to the Aanderaa Data-logging systems. Other lengths, or separate plugs and cables are available on request.

PIN CONFIGURATION

Receptacle, exterior view; bushing = ○; pin = ●

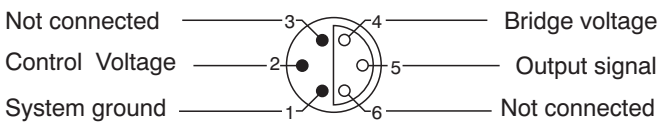

CALIBRATION

Serial No: _____

The sensor is calibrated at 0% and 99% RH. 0% RH is obtained in a vacuum chamber and 99% RH in a chamber with moisture saturated air. The sensor is connected to a Datalogger 3660, giving the following raw data readings (N): The sensor readings are also compared with a psychrometer, Lambrecht Type 00.07610.000012. No. 670773.001.

| | | |
|------------|---|----|
| %RH | 0 | 99 |
| Reading, N | | |

These readings give a set of coefficients used when converting a sensor reading to engineering units.

The coefficients are:

| | | | |
|---|--|---|---|
| A | | C | 0 |
| B | | D | 0 |

To convert raw data to engineering units use the formula:
 $\%RH = A + BN + CN^2 + DN^3$.

Date: Sign:

Representatives Stamp

Latest version is on the Internet

PO BOX 160, NESTTUN
5852 BERGEN, NORWAY

NESTTUNBREKKEN 97
5221 NESTTUN, NORWAY

TEL. +47 55 109900
FAX. +47 55 109910

E-MAIL: info@aanderaa.no
WEB: http://www.aanderaa.com